



FINE
FIXTURES

FOR A LIFE OF STYLE™

DAKOTA

WT20RM

FEATURES

Rimless flush

3 1/8" fully glazed trapway

Compatible with concealed tanks

SIZE 21.25" x 14" x 14.4"

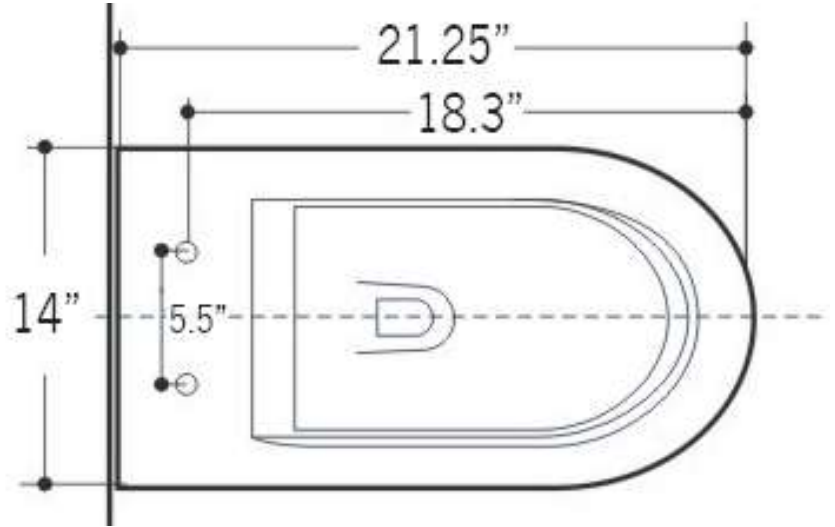

FOR A BATH THAT'S
FLUSH WITH STYLE

Immerse yourself in clean, green luxury with Fine Fixtures' ultramodern wall-hung toilets in the new Nebula™ collection. Our vision of efficiency and space-saving style, each model mounts to the wall with hidden plumbing for a sleek, compact appearance. For the perfect pairing, you can also select our powerful Vortex™ double-swish toilet bowl technology that delivers deeper sanitation while conserving water, reducing clogging, and polishing bowls to a pristine clean. Add soft-close seats and self-clean glazing, and your bath becomes home's centerpiece.

UNDERSTANDING OUR
VORTEX™ DOUBLE-SWISH

Fine fixtures' pioneering Vortex™ technology promises maximum performance while maintaining modernist efficiency. Rimless bowls feature powerful washdown jets that direct water in a consistent cyclonic stream. The result is double the clean with every single flush.



REVOLUTIONARY
DESIGN

Wall-hung toilet units feature powerful Vortex™ technology built right into the bowl.



CONTEMPORARY
PROFILE

Hidden Nebula™ tanks feature seamless mounting for a minimalistic beauty.



CHIC
AFFORDABILITY

Clean, green, eco-friendly performance now comes at an attractive price.